

The switch-mode power supply

Introduction

Almost all modern electronic products depend on switch-mode power supply circuits to convert one power supply voltage to another. For example, to convert from 240 V mains to ~ 3 V required for an LED light, or to produce the several voltages needed inside a phone from its battery.

These circuits are efficient and compact, and embody some nice physics. In this experiment you will construct a switch-mode power supply and use the oscilloscope to help understand its operation.

Your finished circuit should be able to produce an output of tens or hundreds of volts, starting from a 1.5 volt AA battery.¹

1 Inductor + switch

The circuits we are considering rely on the voltage v across an inductor of value L being proportional to the rate of change of the current i :

$$v = -L \frac{di}{dt} \quad (1)$$

Hence we can make a high voltage by causing the current in an inductor to change rapidly.

Build the circuit shown in figure 1. Be sure to use the terminals on the inductor that connect to the 10-turn winding (there should be no other winding present), and check that the two halves of the ferrite core are tightly held in place with a rubber band. There is a separate page to help you identify the components.

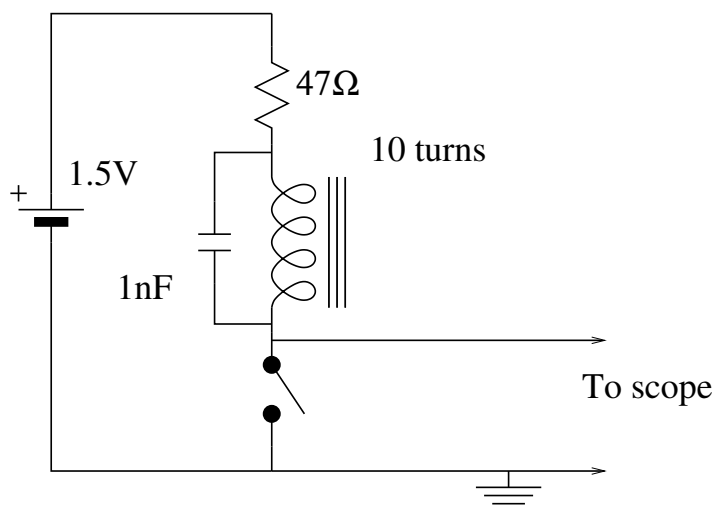

Figure 1: A switched inductor circuit

¹The voltage may be high, but the energy handled by the circuit is too small to do you any harm

Use the oscilloscope to look at the voltage across the switch. A suitable starting setup might be 2 volts per division vertically (DC coupled) and 10 ms per division horizontally; but you will need to change this frequently.

Take note of:

- The voltage when the switch is open
- The voltage when the switch is held closed
- Transient effects, i.e. spikes and oscillations that occur at the moment of contact or release (look carefully).

To get a better view of the transients, use "normal" not "auto" triggering, adjust the trigger level control so that the trace updates when you operate the switch in your circuit, and speed up the timebase. The scope's memory will capture the transient. Examine the waveform using appropriate amplitude and timebase settings. Produce a graph showing as much quantitative detail as you can, for example: period, decay rate, peak height. Write down also an *explanation* of your observations: why are the voltages and timescales as they are? Q

The **scopedump** application can help by capturing and printing the data from the scope, but you will still need to annotate it clearly. Figure 2 shows an attempt at sketching the waveform. Yours will differ in detail.

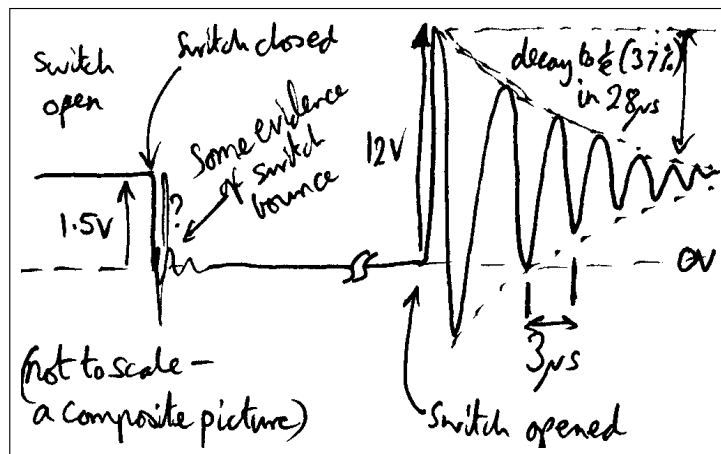

Figure 2: A sketch of the waveform produced by figure 1

The decaying oscillations are controlled mainly by the inductor and the 1 nF capacitor. Use your measurement of their period to estimate the value of the inductor. Recall that in the formula for the resonant frequency,

$$\omega = \frac{1}{\sqrt{LC}}, \quad (2)$$

$\omega = 2\pi f = 2\pi/T$. Discuss your conclusions with a demonstrator, especially if you cannot see, or explain, the voltage spikes and oscillations.

2 LT1073 boost converter

This part of the experiment uses the same battery and inductor as the previous part, but the switch between the inductor and ground is replaced by a transistor switch inside an LT1073 integrated circuit, which is a chip made for use in switching power supplies.

Dismantle the first circuit and build the circuit shown in figure 3. For the sake of the chip, double check the value and connections of all components. In addition to the chip and the inductor, the circuit includes some resistors that set the operating parameters, and a diode and capacitor whose job it is to catch the transient voltage across the inductor, and store its energy.

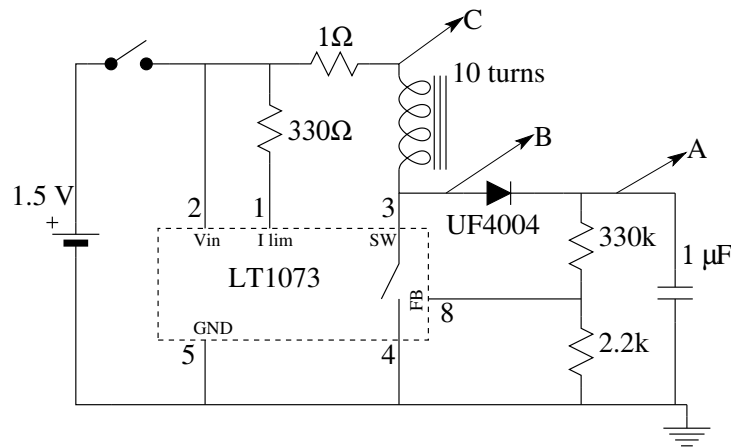

Figure 3: Boost (step-up) converter using the LT1073 chip. The dashed box represents the LT1073. The switch shown between pins 3 and 4 is internal to the chip. The locations of the numbered pins of the chip are not their physical positions: they have been moved to make the circuit easier to follow.

With the scope set to **auto** trigger, close the switch and hold it closed². You should see roughly 30 volts dc at point A, which is not bad considering the 1.5 volt battery. If you don't see the expected signal, check your circuit. The most likely cause of problems is a wrong or faulty connection. Defective components are much less likely.

Record the waveform at point A, paying attention to the small sawtooth-like ripple (having a period of a few ms) as well as its overall height. Switch the scope coupling to **AC** and increase its sensitivity to see details of the ripple. Careful adjustment of the trigger level control will help. You can freeze the display with the **run/stop** button.

To see why the output behaves this way, connect the second scope channel to point B, and display it below the waveform at point A (suggested settings: ch1: 0.5 V AC, ch2: 1 V DC, 2 ms). Comparing figures 1 and 3, convince yourself that point B should show similar behaviour to that seen in the first circuit. When point B is at 1.5 V, the switch inside the LT1073 is open, so no current flows in the inductor. When the switch closes, point B goes to zero volts, and current builds up in the inductor. When the switch opens again, the voltage at point B *exceeds* the battery voltage momentarily, as the current, and thus the flux, in the inductor collapses. Label your plot of the waveform at point B to indicate these

²Since now the switch is used just to connect the battery; the switching of the inductor is done internally by the chip

features. If your waveform doesn't seem to follow this description, consult a demonstrator.

The manufacturer describes the operation of the LT1073 thus:

“The LT1073 is a gated oscillator switcher. This type of architecture has very low supply current because the switch is cycled only when the feedback pin drops below the reference voltage...”

You should see the effect of this “gated” operation on the scope. All the time that point B sits at 1.5 volts, the chip and inductor are inactive. All that happens is that the capacitor slowly discharges through the 330 k Ω and 2.2 k Ω resistors. Use the formula for the exponential discharge of a capacitor through a resistor,

$$V(t) = V(0) \exp - \left[\frac{t}{RC} \right] \quad (3)$$

to calculate by how much the voltage at point A should fall during this time. Compare your result with the actual fall in the voltage at point A, i.e. the amplitude of the ripple you see there.

The chip uses pin 8 (the “feedback” pin) to watch the output voltage. When it has fallen below a certain threshold, the chip springs into action and rapidly opens and closes its switch one or a few times. Each opening of the switch produces a voltage spike which causes current to flow through the diode, charging the capacitor. Identify in your plot the step in capacitor voltage caused by each opening. Question: how big does the spike have to be in order to be conducted through the diode? Q

Sections 3, 4 and 5 suggest some further investigations. Do as much as you can, but quality beats quantity.

3 Tracking the energy flow

In the circuit of figure 3, measure the current in the inductor, by moving the second scope probe from point B to point C. If we assume that the voltage at the battery side of the 1 Ω resistor is constant (around 1.5 V), then the amount by which the voltage at the other side of the resistor (point C) drops below this will be a measure of the current in the resistor (by Ohm's law), and also the current in the inductor. Sketch the waveform at point C, showing how it relates to that at point A.

Use the expression $E_L = \frac{1}{2}LI^2$ to work out how much energy is stored in the inductor when the current is at its peak. Compare this with the energy transferred to the capacitor, as measured by the corresponding step in its voltage ($E_c = \frac{1}{2}CV^2$, so $\Delta E_c = CV\Delta V$). Determine how many times per second this happens, and hence how much power is transferred through the circuit. Is your result consistent with the amount of power that is dissipated by the 330 k Ω resistor, given the average voltage across it?

4 Higher voltages

The difficulty in extending the circuit of figure 3 to provide still higher voltage is that the chip will be damaged if pin 3 is exposed to more than 40 V. Adding a second winding to the inductor solves this problem. Because both the new and the existing winding will be on the same core, they will experience

the same rapid flux changes, but if we use a larger number of turns on the secondary winding, the e.m.f. induced in it will be larger. Why? Q

Decide on a number of turns for the secondary winding (30 or so, since the primary has 10) and get a piece of enameled copper wire of about the right length. Scrape the insulation from all around the end 1 cm of the wire using a craft knife (carefully!) and coat the bared wire with solder (“tin it”) by bringing the soldering iron bit and solder into simultaneous contact with the wire. Remove the ferrite core from the inductor and solder the wire to the top side of a spare contact pin, using a tiny amount of fresh solder. Wind the secondary neatly on the former, and repeat the procedure for soldering the second end to another pin.

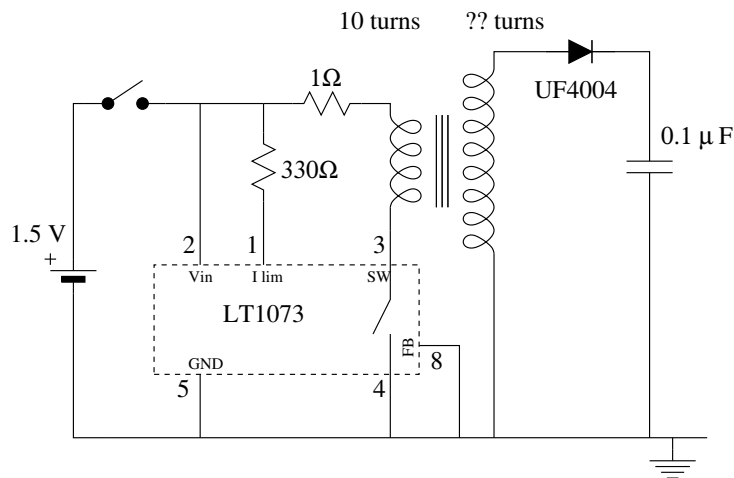

Figure 4: High voltage flyback converter. Note the changed output capacitor

Reassemble the inductor (now it is a transformer), and modify your circuit, as shown in figure 4. Temporarily omit the UF4004 diode and use an oscilloscope probe *set to the x10 position* to look at the voltage at the free end of the secondary winding. You should see big voltage spikes when the circuit is switched on. Remember that with the scope probe set to x10, the scope sees only one tenth of the voltage at the end of the probe. Sketch the waveform you see. You may have to look hard to see the biggest spike — the large $\frac{d\phi}{dt}$ does not last for long. If the spike is predominantly negative in sign, reverse the secondary connections so that it is positive and will be conducted by the diode (why is the waveform not symmetric)? Q

Connect the diode and capacitor and measure the voltage across the capacitor. To verify that you really do have a high voltage, connect a neon lamp in parallel with the capacitor. The neon will not start to conduct until at least 60 V is applied to it (why?)

5 Relaxation oscillator

The neon lamp in section 4 can be made to flash using a further resistor and capacitor, as shown in figure 5. It may take some adjustment to the component values, but the lamp should flash at a visible rate.

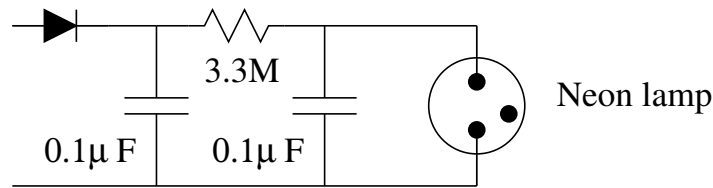

Figure 5: Neon oscillator added to the flyback converter

With the scope probe set to $\times 10$ (to avoid loading the circuit), observe the voltage across the neon lamp. It is instructive to look at the starting of the circuit (with discharged capacitors) as well as the steady-state behaviour. Record your trials and observations. Can you explain the oscillations? It may help to know that the condition for the neon to become conducting (sufficient voltage) is different to the condition for it to *stay* conducting (sufficient current in the gas). **Q**

6 Checklist

Your lab book should contain:

- A *short* explanation of what the experiment is about.
- Circuit diagrams of all circuits you built, showing component values. Drawings and explanations of any changes you made and anything else you constructed (e.g. the secondary winding).
- Sketches of all waveforms you observed, labelled with voltages, times and correlation with other waveforms. Notes of conditions under which the measurements were made.
- Explanations of what you discovered about how the circuits worked.
- Calculations of voltages, energies, etc., and answers to questions as suggested in this manual (generally marked with a **Q**). Assessment of whether the calculations yield the expected results, to within the expected accuracy.

MSC 2013-10-03
MSC 2019-10-05