

Handling Small Signals

Aims of this experiment

- Characterise a x1000 instrumentation amplifier, using the gain to identify typical interference.
- Use the instrumentation amplifier to read out a strain gauge Wheatstone bridge.
- Use amplification with high- and low-pass filtering to measure your pulse rate optically.

In many experiments, the signals that have to be measured are very small: millivolts, microvolts or even nanovolts (10^{-9} V). In this experiment, you will build an amplifier and filters that allow such signals to be seen, and separated from interfering signals. You will use various signal sources, including your own pulse, and learn to identify and reduce different sources of interference.

1 The instrumentation amplifier

This experiment uses an instrumentation amplifier chip. While both the chip and its circuit symbol look superficially similar to the operational amplifiers that you may be familiar with, the instrumentation amplifier is different internally, and is intended to provide amplification in measuring instruments.

The circuit shown in Fig. 1(b) uses an INA121 instrumentation amplifier. Unlike an op-amp, it requires no external feedback components, just a single resistor R_G to programme the gain G . For the INA121, $G = 1 + 50 \text{ k}\Omega/R_G$. We are using $R_G = 51 \text{ }\Omega$, for a gain of approximately 1000.

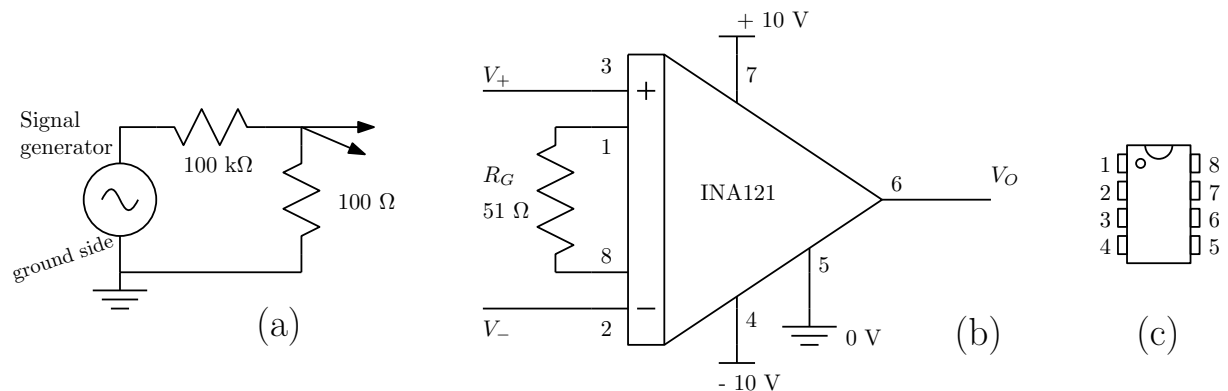

Figure 1: (a) Signal generator and potential divider used for testing; (b) Instrumentation amplifier circuit; (c) INA121 pinout. The arrowed connections represent the input arrangements described in the text.

The main feature of the instrumentation amplifier is that the output voltage, V_o is given by the programmed gain multiplied by the difference between the voltages at the inverting and non-inverting inputs:

$$V_o = G(V_+ - V_-). \quad (1)$$

Build this amplifier neatly on a breadboard, and use a 4 mV peak-peak, 1 kHz sine wave to verify it has the correct gain. A way of making this small voltage is shown in Fig. 1(a), where a potential divider

reduces the size of a 4 V p-p signal, before the amplifier increases it. Using two oscilloscope probes, document the waveform at the signal generator, the input to the amplifier, and the output of the amplifier. Connect the signal from the potential divider to the amplifier in three different ways:

- Signal to the non-inverting (V_+) input, with the inverting input (V_-) grounded.
- Signal to the inverting (V_-) input, with the non-inverting input (V_+) grounded.
- Signal to both the (V_+) and the (V_-) inputs connected together (a "common mode" signal)

According to Equation 1, the gains should be approximately 1000, -1000 and 0 respectively. Are your measurements acceptably close? In order to see any deviation from zero in the third case, you will need a much bigger input signal, so in this case you can dispense with the potential divider and connect the signal generator directly to both inputs. The output/input ratio in this case is called the "common mode gain (G_{cm})", and should be much less than 1. The ratio G/G_{cm} is a figure of merit called the common-mode rejection ratio. The INA121 data sheet claims this should be 10^5 under our conditions. Your measurement will probably fall somewhat short of this, because of asymmetries introduced by the breadboard construction.

2 Measuring small signals

2.1 Induced EMF

Remove the signal generator and potential divider, and use as a signal source a loop of wire of diameter 4-5 cm. The loop should be connected between the V_+ and V_- inputs, but one of them must also be connected to ground – the amplifier requires the inputs to have a defined potential with respect to ground. Pass a small magnet in and out of the loop, using the amplifier and oscilloscope to observe the induced EMF, see Figure 2

The field at the surface of a strong permanent magnet is around 0.2 T. Work out whether the size of the induced EMF you measure is consistent with this (only an order of magnitude calculation is needed).

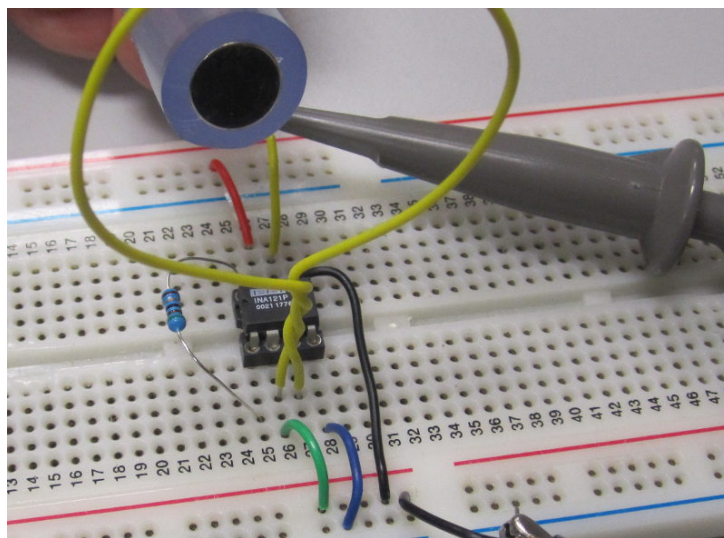

Figure 2: Detecting a moving magnet

2.2 Interference hunting

You may see some interference superimposed on the induced EMF signal. To examine this more closely, replace the wire loop by the 1mH inductor on long wires that is provided (see Figure 3), and use it as a pick-up coil to go interference hunting. You should find strong magnetic interference near the cables powering your equipment, and also being emitted from power supplies inside the equipment. Characterise this interference in terms of frequency, waveform and amplitude, using the oscilloscope. You will need to look on a wide range of time scales, and may find that setting the trigger source to “Line” (i.e. mains frequency) is helpful when looking for mains-derived interference. Give an explanation for the different components of the interference that you can see.

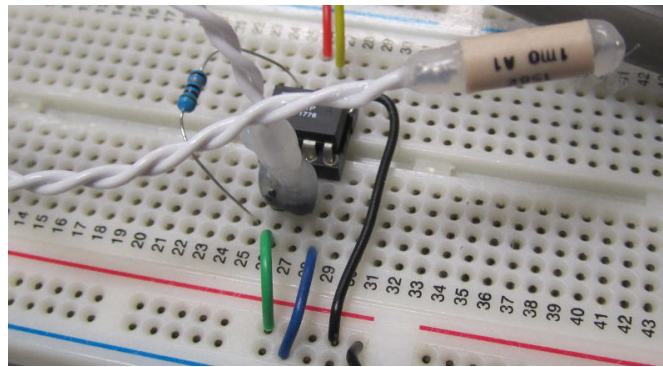

Figure 3: The cream-coloured 1 mH inductor serves as a pick-up coil

2.3 Strain gauge bridge

The two complementary inputs of the instrumentation amplifier make it ideal for reading out a Wheatstone bridge. Our signal source for the instrumentation amplifier is a simple weighing device configured as a bridge. You are provided with a flexible steel ruler that has a strain gauge glued to each side. *Handle it gently*, because the strain gauge wiring is fragile. A strain gauge is a resistor made from a thin metal foil. When it is stretched, the change in length causes a change in resistance. The strain gauges, along with other resistors on the attached plug, form the bridge circuit shown in figure 4.

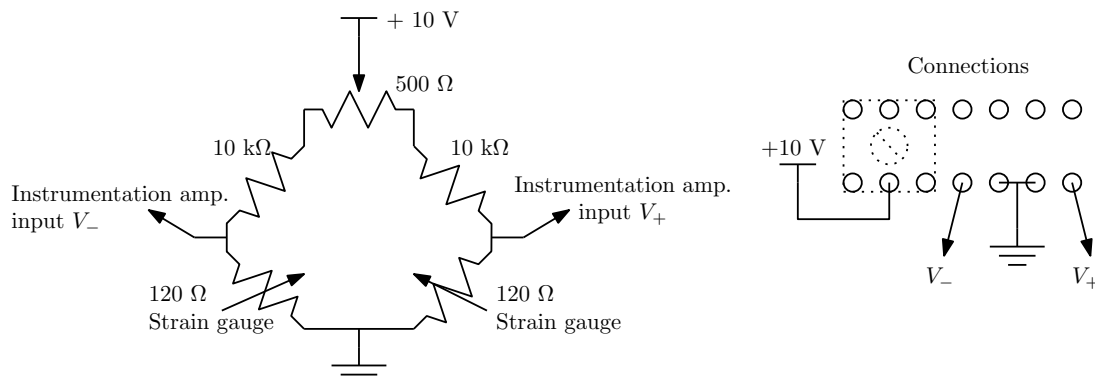

Figure 4: Strain gauge bridge

When the ruler is bent slightly, the resistance of one of the strain gauges will increase and that of the other will decrease. The changes in resistance may be only a few hundredths of an ohm, in a resistance of 120Ω . Nevertheless, the instrumentation amplifier will allow this small change to be seen. Connect the bridge to the amplifier as shown in the figure. Fix the wired end of the ruler to a rigid support, and balance the bridge by adjusting the potentiometer built into the bridge plug so that the output of the amplifier is zero volts dc. When the ruler is flexed slightly, the amplifier output voltage should change. Use the ruler to “weigh” some coins.

How much differential voltage change *at the bridge* is caused by the weight of a 10p piece? How big is the common-mode voltage in this circuit? Estimate the smallest fractional change in resistance you could measure with the circuit. Why is the performance better than you could get with a single strain gauge and an ohmmeter?

3 Filtering and optical pulse detection

Every time your heart beats, the density of blood in your fingertips changes slightly, and with it their colour. Obviously, this is not a big effect, but with suitable signal processing, you should be able to see it.

3.1 Reflective Optical Sensor

The OPB745 optical sensor is normally used to detect objects moving past it. It contains an infrared light-emitting diode and a phototransistor.¹ We will use it to sense small changes in reflectivity. Build the circuit shown in Figure 5, which we will shortly connect to the INA121. Figure 7 shows how the sensor can be placed on a breadboard.

Check that the voltage at the $10\text{ k}\Omega$ resistor in Figure 5 varies between approximately zero and 10 V as a piece of paper is moved towards the sensor. Explain why this happens.

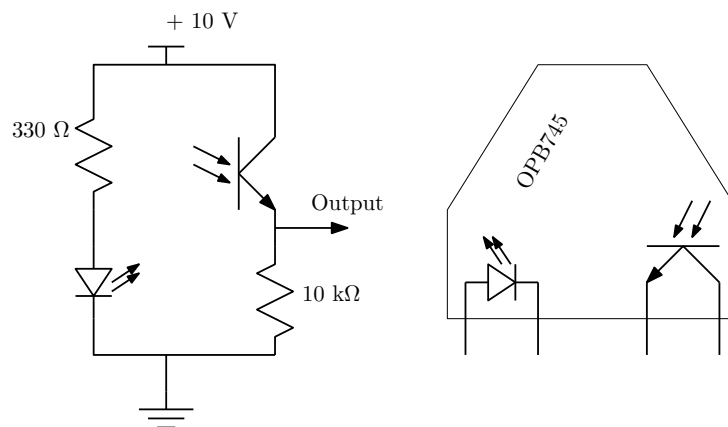

Figure 5: Optical sensor

¹The OPB745 actually has a photodarlington transistor for greater sensitivity

Check that when you put a fingertip on the sensor, the voltage is well clear of these limits, say in the range 2-8V. If this is not the case, change the resistor to one of a more appropriate value, so the voltage has headroom to fluctuate up and down.

3.2 AC coupled amplification and filtering

The fluctuations in voltage caused by the blood content of your finger are tiny, and must be amplified; but we cannot amplify the constant voltage on which they are superimposed, because the amplifier output would need to reach hundreds of volts. One solution is to *AC couple* the signal to the amplifier via a capacitor. Connect the sensor output to the INA121, as shown in Figure 6 (without C2). Note that the Value of R_G is different in this circuit When you gently rest a finger on the sensor, the amplifier output should make a large excursion, before returning close to zero volts. Explain why this happens, and what determines how long the output takes to settle.

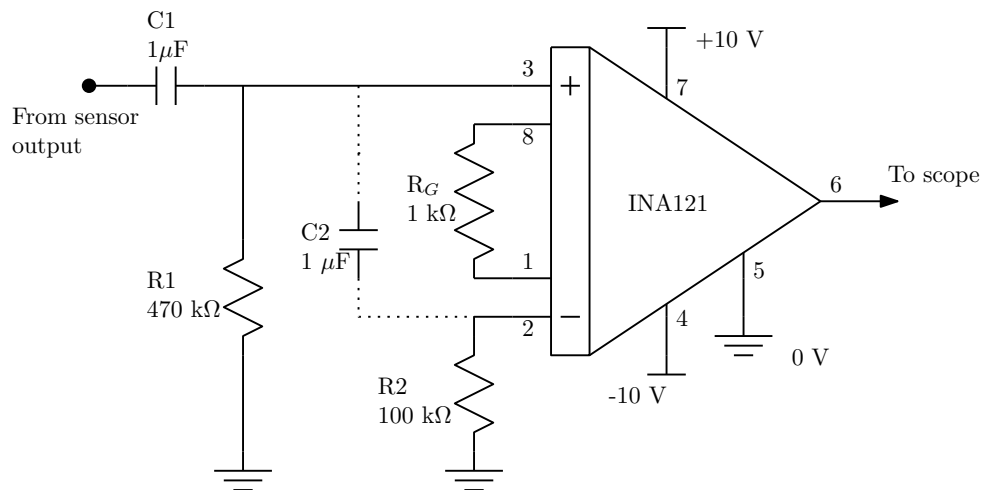

Figure 6: Amplifier for the optical sensor. Do not connect C2 at first.

With a little practice, you should see the regular beats of your pulse at the amplifier output, see Figure 8. Relax your hand and don't press hard, as there has to be some blood in your finger.

The pulse signal will probably be accompanied by some higher frequency interference. Check this with the scope, and try installing C2 to remove much of the interference. How does this work? What is the range of frequencies amplified by the final circuit, and why does this help obtain a clean output?

4 Checklist

Your lab book should contain:

- Diagrams of circuits you built
- Waveforms, observations and explanations as prompted by this manual.
- Enough detail to enable someone to quickly pick up the thread of what you did and observed.

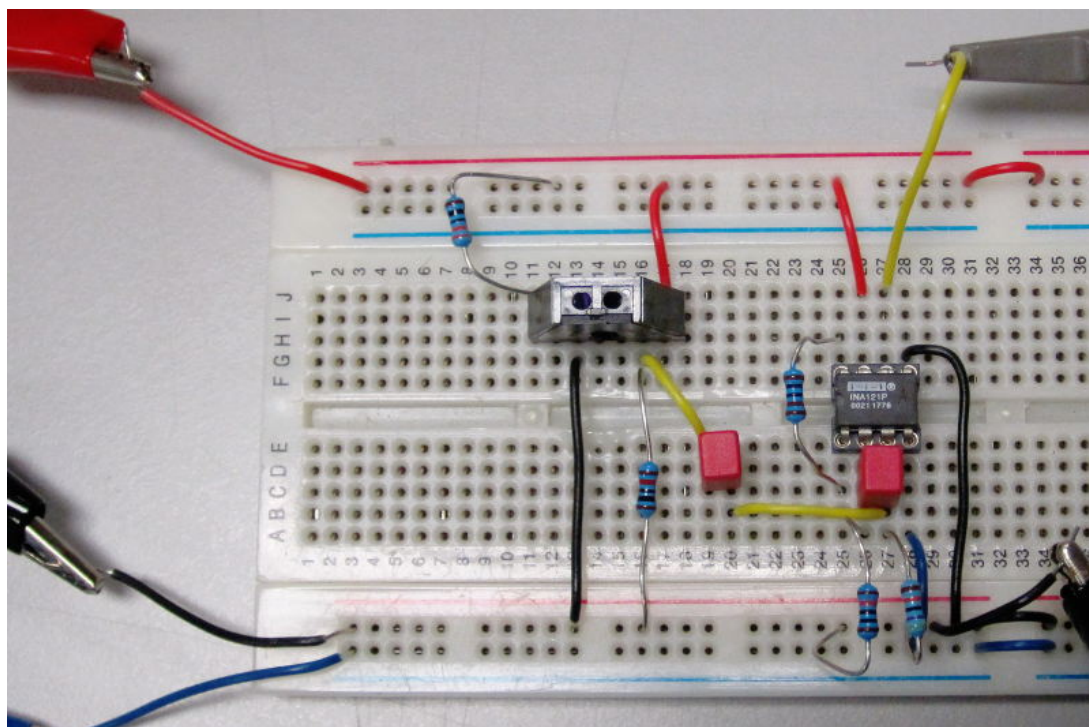

Figure 7: Sensor and amplifier

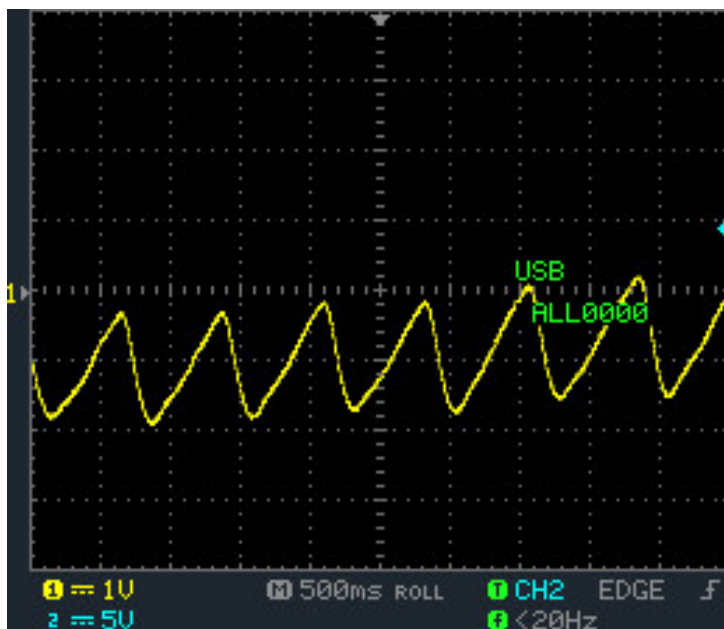

Figure 8: Pulse of demonstrator

MSC 2017-11-15